



July 2024

Auto Weigher





Auto Weigher

Automated and remote weighing for simplified livestock management



Watch:

CLICK HERE TO WATCH

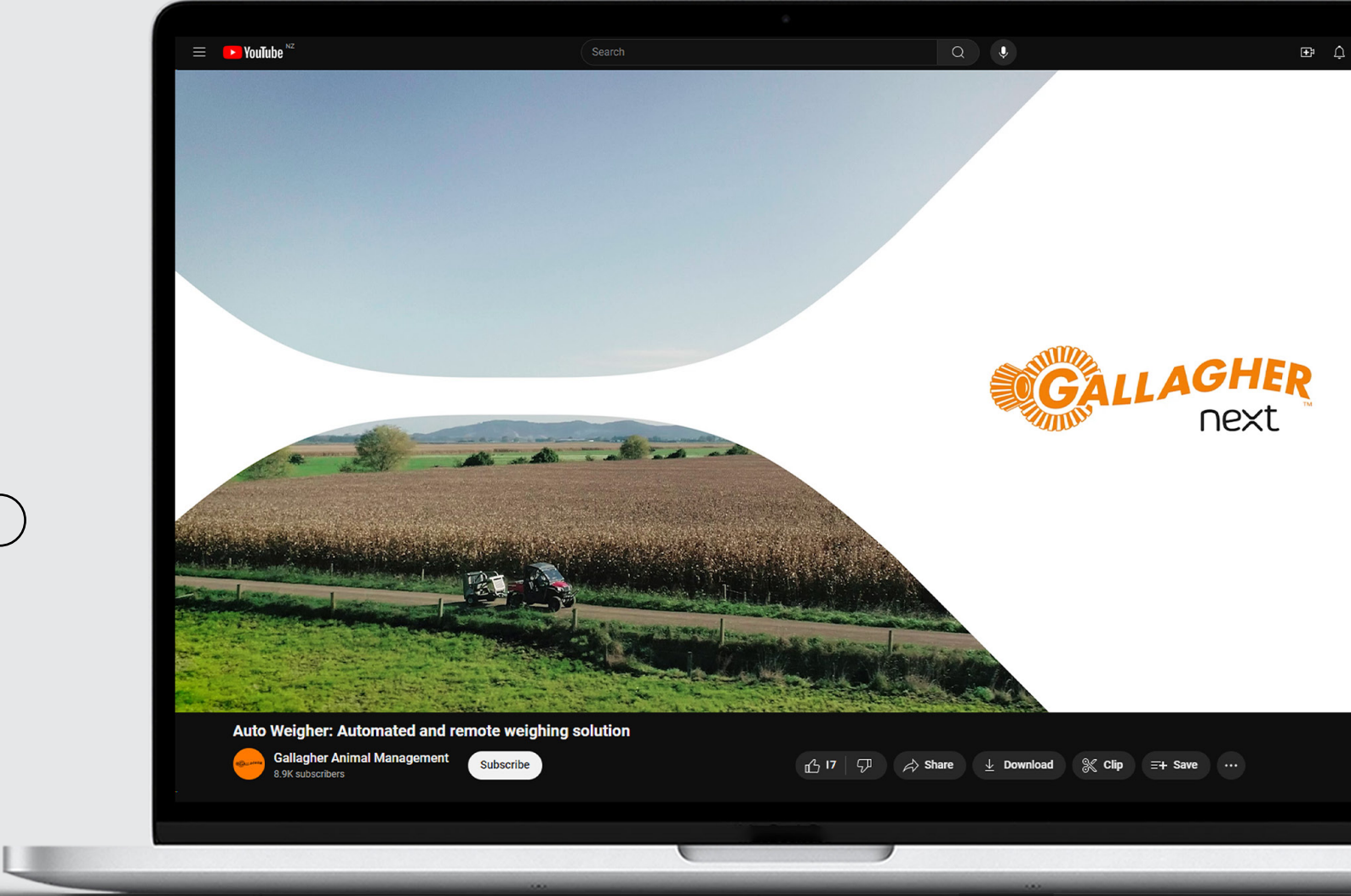



As more farmers seek to harness the power of real-time information and data on farm, Gallagher Animal Management has partnered with an emerging cattle management business to unleash the benefits of remote weighing for livestock farms all over the world.

Irish-Canadian based StrongBo AgriTech has developed a remote weighing system which allows livestock to be weighed in paddocks, rather than having to walk into the yards.

The units are manufactured in Canada.

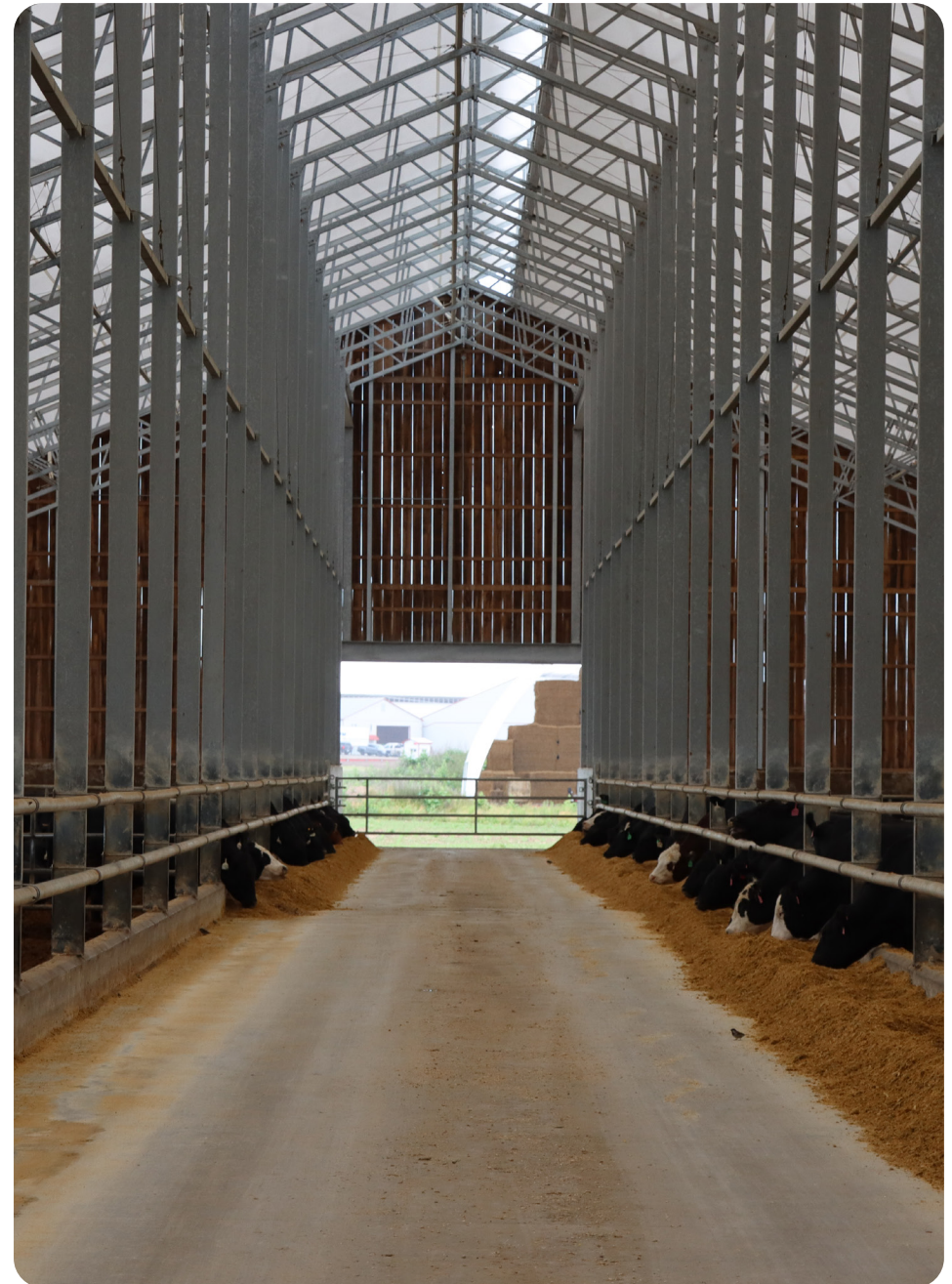

Key Benefits

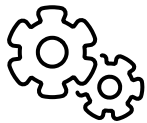

Automated and hassle-free weighing.

Weigh more frequently without the extra trips to the yards. Less manual labour for you, less stress for your animals.



Animal data at your fingertips.

Partial weight data is captured and then converted to full body weight. This data is then sent securely to the Cloud. Easily access animal data on your mobile or desktop.



Impactful insights for improved performance.

Easily identify low performers with the help of easy-to-understand graphs. Make proactive management decisions sooner, saving you time and money.



Farm and cattle-tested.

Proven farm-tough and works with animal behaviour. The machine is engineered to withstand harsh farming environments.



Farm tough

Fully enclosed load cells for accurate weights all the time

Rugged and reliable, the fully enclosed and protected load cells ensure accurate weights in any environment or farming condition, shielded from rain, dirt, mud, or manure.

How it works



01

Assemble and commission the unit as per the supplied Quick Start Guide. Take the unit to your cattle; it is highly portable and set up only takes a few minutes.



02

Put an attractant like a salt block or molasses in the integrated trough which will entice the animal to voluntarily step on the platform.

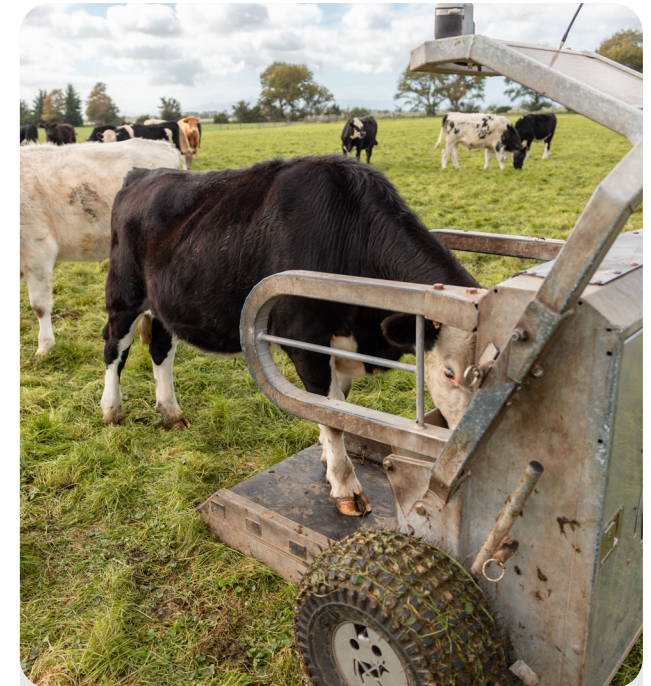

03

The integrated EID reader identifies the animal. The Auto Weigher samples the weight applied onto the platform and an algorithm converts this to an estimated full body weight.



Session
West Hill Paddock

Session average
438

Session animals weighed
73

ADG
0.75

High Growth Rate !

Latest session distribution

Day	Count
10	2
12	3
14	4
16	2
18	1.5
20	1
22	3

400kg 425kg 450kg

04

The collected EID and full body weight data are then transmitted to the cloud and information is sent to the app.

05

View the data on the app. It displays easy-to-understand data such as individual or group weights and growth over time reports.

Mobile App



The information on the app will update periodically throughout the day. Checking the app once a day should provide our farmers and ranchers with the data they require. Please note that we are reliant on the animals weighing themselves. It will also take 7 days to get the rolling average. However, individual animal data will show in the app when the animal steps on the platform and the calculated weight is transmitted to the Cloud.

Disclaimer: The StrongBo app is regularly being updated and improved so some screens on the app may appear a little different to those shown.

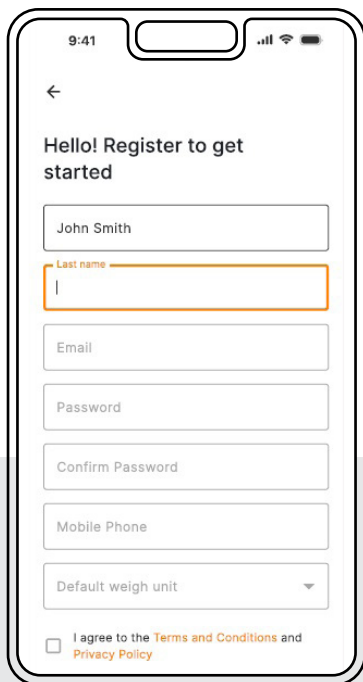

Registration

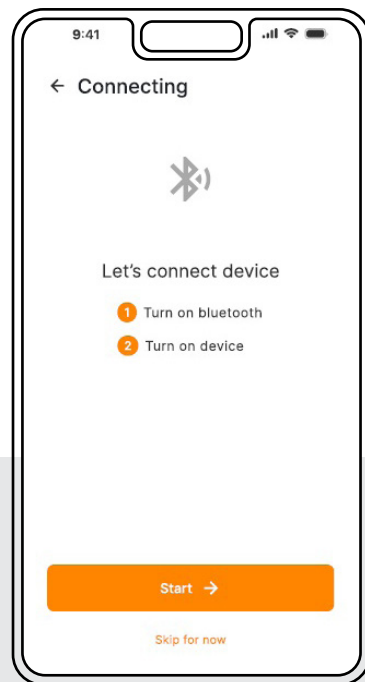

Connecting to the unit

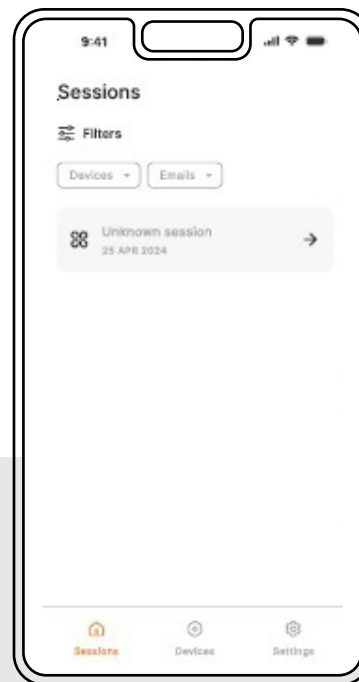

Sessions View

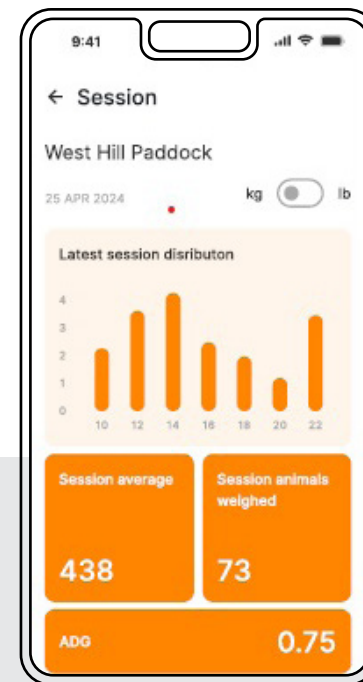

Sessions Details

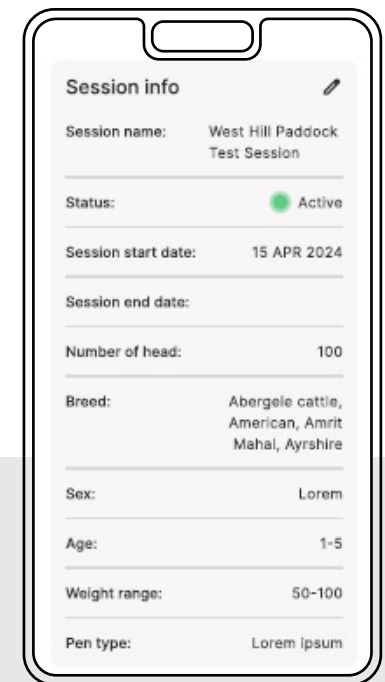

Editing a Session

Power and connectivity

The Auto Weigher has cellular connectivity and is hardware-ready for satellite. This dual communication mode will give our farmer end users peace of mind knowing they can weigh their animals even in the most remote location.

Switching from cellular to satellite (or from satellite to cellular) will not require any action from the end user. We have automated the process so it will all look seamless from their end!

It is powered using a 12V battery and the integrated solar panel ensures that the battery is always charged and operational.



Product Technical Information



**2 Year
Warranty**

The warranty begins from the date of purchase from Gallagher or a Gallagher-approved distributor or reseller.

Weight: 400kg

Material: Galvanised steel

Other parts material: Stainless steel, aluminium

Tow Hitch Ball Size: 2"

Wheel Diameter: 22"

If you need a full Product Technical Specification Sheet, please contact Gallagher.

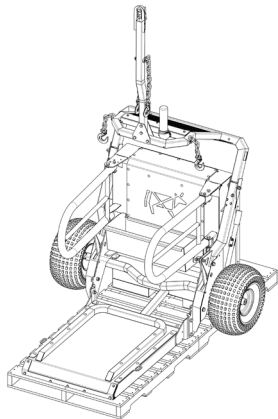

Weigh-Ready Dimensions

1.66m x 1.689m x 2.6m (L x W x H)

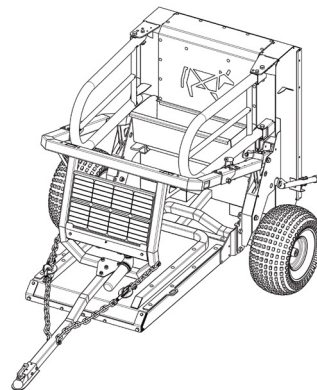

Tow Dimensions

2.85m x 1.689m x 1.437m (L x W x H)

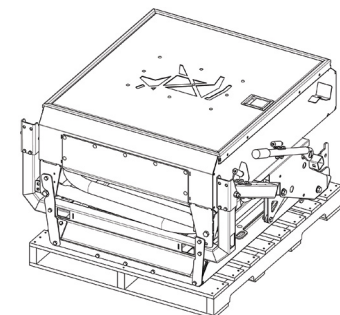

Shipping Dimensions

1.219m x 1.150m x 0.865m (L x W x H)

